

OPERATING & SERVICE PARTS MANUAL
FLOOR MODEL OVERWRAPPERS



Model 107A



Model 112A

AXLE MOUNT MODELS:

MODEL 102A

TWO ROLL CAPACITY WITH MOUNTING AXLES
SPLASH SHIELD AND 6" X 15" HOT PLATE

MODEL 104A

THREE ROLL CAPACITY WITH MOUNTING AXLES
AND 8" X 15" HOT PLATE

MODEL 107A

THREE ROLL CAPACITY WITH MOUNTING AXLES
SPLASH SHIELD AND 8" X 15" HOT PLATE

MODEL 112A

COMPACT THREE ROLL CAPACITY
MOUNTING AXLES AND PACKAGE REST

MODEL 112AHP

COMPACT THREE ROLL CAPACITY
MOUNTING AXLES AND 6" X 15" HOT PLATE

READ ALL INSTRUCTIONS CAREFULLY BEFORE OPERATING EQUIPMENT

TABLE OF CONTENTS



Film Threading & Mounting	3
Recommended Maintenance	4
102-104-107A Schematic & Parts List	5
112A & 112AHP Schematic & Parts List.....	6
Troubleshooting Guide	7
Electrical Service Information	8
Electrical Schematics.....	9
Electrical Box & Hot Plate Schematic & Parts List	10

FILM THREADING & MOUNTING



THREADING THE FILM:

Thread the film as shown, one at a time or as needed.

MODEL 102A

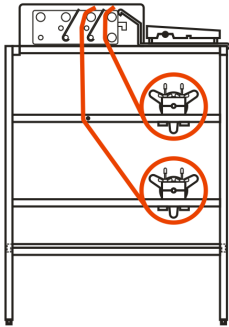

MODEL 107A

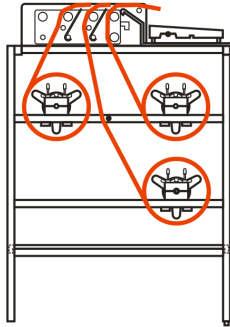

MODEL 104A

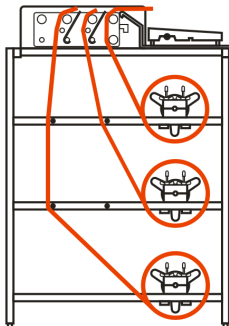

MODEL 112A

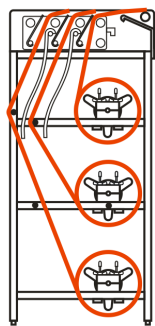

FILM SELECTOR

Pull different sized films into film selector and drape unused film in front of roller.

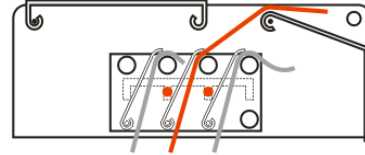

TO CHANGE FILM WIDTHS:

1. Lift up both handles
2. Move evenly forward or backward
3. Lower into slots

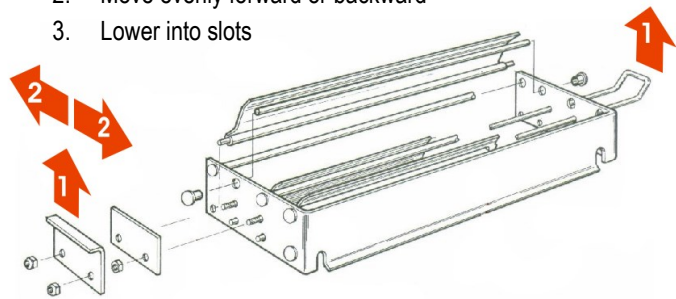

MOUNTING FILM ON AXLE

1. Loosen four wing nuts (A)
2. Swing out upper bearing blocks (B) on both sides
3. Lift out axle assembly (C) and unscrew movable end cap (D), position fixed end cap (E) for correct film width then secure with pin (F) and o-ring (G)
4. Position the cardboard core of the film roll against the taper of the fixed end cap. Make sure the film is threaded from the bottom of the roll and under film roller (H) (see threading diagrams)
5. Replace adjustable end cap (D) and screw on tightly
6. Replace the axle assembly (C) and film roll onto the lower bearing blocks (J), swing upper bearing blocks (B) back into place and tighten and adjust wing nuts (A) for desired film tension

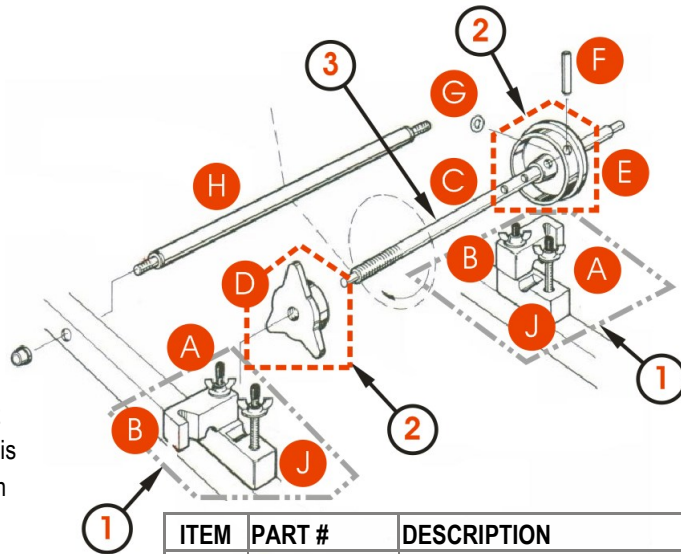

ITEM	PART #	DESCRIPTION
1	6305-018	Bearing Block Set, Includes: Upper Bearing Block, RH Upper Bearing Block, LH Lower Bearing Blocks
2	6110-023	3" Core Adapter Set Includes: 3" Adjustable Core 3" Fixed Core
3	3005-004 3005-047	Core Axle, 21 15/16" L Core Axle, 24" L

Revised 2017

RECOMMENDED MAINTENANCE



- **MAKE SURE TO TURN OFF THE UNIT, PULL THE PLUG AND LET THE MACHINE COOL DOWN BEFORE CLEANING ***

NON-STICK COVER & HOT PLATE

- It is recommended to replace the Non-stick cover at least once every three months to protect the heating foil and maintain a sanitary surface. The Non-stick cover is used to create a sanitary, stick free surface to seal film with the hot plate. Non-stick covers are porous, meaning liquids or moisture can permeate the cover, get to the surface of the hot plate, and burn off on the hot plate.
- It's recommended that the Non-stick cover be replaced every three (3) months or as needed depending on the level of daily wear and tear. The Non-stick cover should be changed if the surface is soiled, or holes, punctures, excessive wear, or damage are present.
- The hot plate can be cleaned, as needed, with a mild spray degreaser, applied to a soft rag or paper towel and then wiped on the plate while cold.

CUT OFF ROD

- Make sure that the unit is turned off and the cut off rod is cold to the touch.
- The film cut off rod can be cleaned, as needed. Cover the unit surfaces with paper towels to protect them from over spray and debris.
- Spray and coat the Cut-off Rod generously with an FDA approved "Degreaser" product.
- After soaking for a few minutes, lightly scrub the surface of the Cut-off rod with a Scour Pad (Scotch-Brite™ type pad).
- Wipe the surface clean of debris and residue with clean paper towels or cloths.

CLEANING THE UNIT

- The machine can be completely wiped down using mild cleaning detergent and soft rags or paper towels. Do not hose down or submerge the unit.

MODEL 102/104/107A REPLACEMENT PARTS



TO REMOVE ELECTRICAL BOX:

- Lift up wrapping bridge (A)
- Remove screws (B) from both sides of electrical control housing (C)
- Lift out electrical control housing

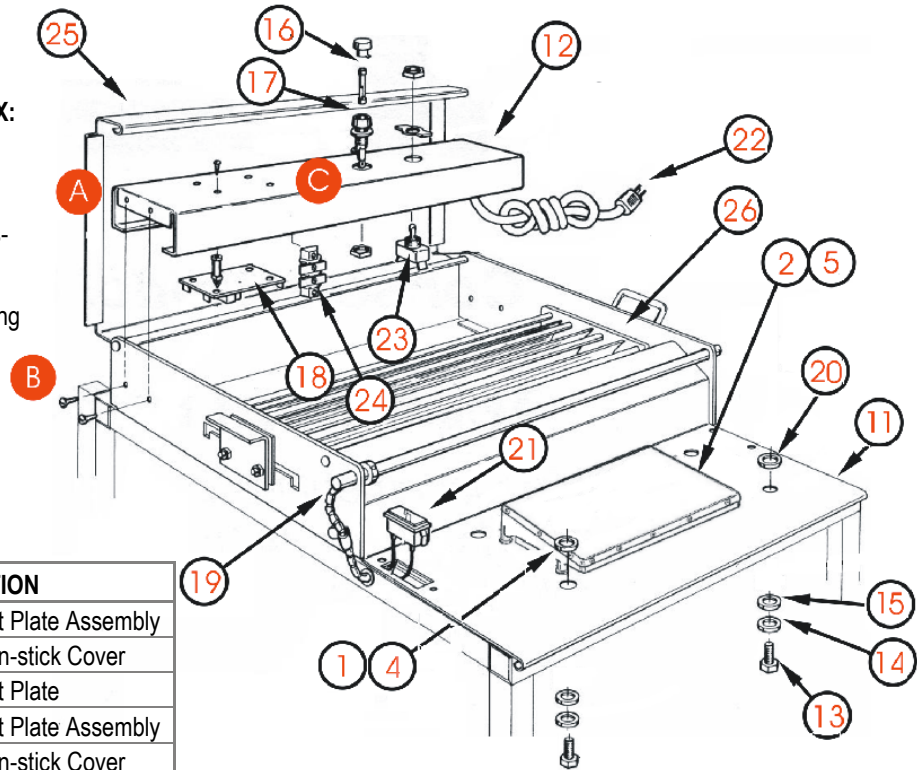

ITEM	PART #	DESCRIPTION
1	6101-020	6" x 15" Hot Plate Assembly
2	5901-011	6" x 15" Non-stick Cover
3	6305-076	6" x 15" Hot Plate
4	6102-043	8" x 15" Hot Plate Assembly
5	5901-001	8" x 15" Non-stick Cover
6	6305-079	8" x 15" Hot Plate
7	2145-005	Thermostat Knob
8	1881-002	Thermostat
9	6110-016	Element Assembly
10	6305-080	Retainer Plate
11	6102-063	Front Plate
12	6102-031	Control Housing
13	1903-188	#10-32 Screw
14	1907-005	#10 Lock Washer
15	1909-026	#10 Flat Washer
16	1821-034	1 Amp Fuse, Slo-Blo
17	1821-013	Fuse Holder
18	1818-001	Control Board
19	1824-011	Hot Rod 23" L
20	1833-002	Insulator Washer
21	1836-002	Pilot Light
22	1851-052	Power Cord
23	1872-008	Toggle Switch
24	1875-002	Terminal Block
25	6102-052	Wrapping Bridge
26	6102-050	Film Selector Assy.

6" X 15" HOT PLATE FOR MODEL 102

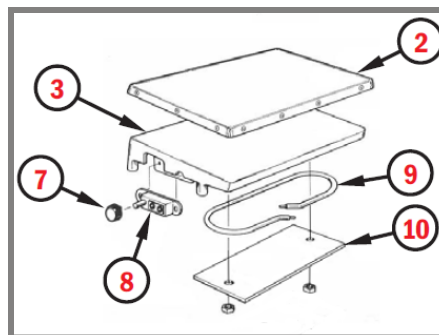

8" X 15" HOT PLATE FOR MODELS 104,107

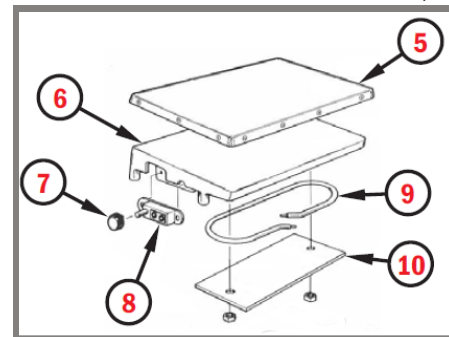

MODEL 112A/112AHP REPLACEMENT PARTS

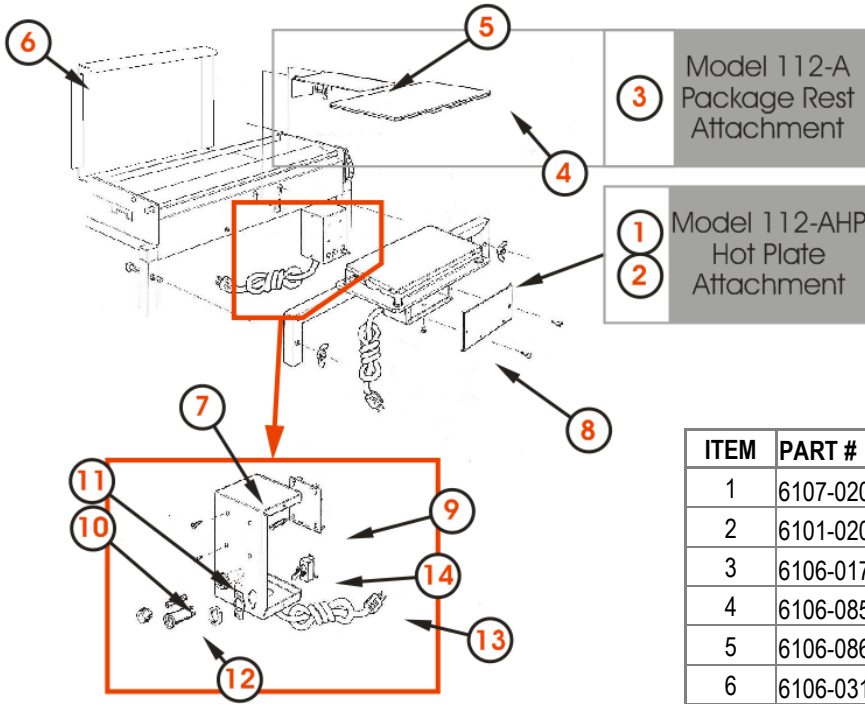

ITEM	PART #	DESCRIPTION
1	6107-020	Hot Plate Assembly Kit
2	6101-020	6" x 15" Hot Plate Assembly
3	6106-017	Package Rest Assy.
4	6106-085	Mounting Bracket
5	6106-086	Package Rest
6	6106-031	Wrapping Bridge
7	6106-081	Control Housing
8	6106-089	Control Housing Cover
9	1818-001	Control Board
10	1821-034	1 Amp Fuse, Slo-Blo
11	1821-013	Fuse Holder
12	1836-004	Pilot Light
13	1851-052	Power Cord
14	1872-008	Toggle Switch

GENERAL QUESTIONS

If new machine doesn't turn on (heat up) what should we do?	Ensure power switch is ON. Check if fuse is blown. Check for loose wires in the electrical box, shipping may loosen wire connections.
My unit is tripping the GFCI?	The wires in the hot plate may be shorting and should be insulated with a high temperature electrical tape. If the thermostat is shorting to ground, replace the thermostat.
What is the standard voltage on wrapping machines?	110V - (220V is available)
Does the Heating Element 6110-016 fit all hot plates?	The element fits the 6 by 15, 8 by 15 and 9 by 12 hot plates. The 6 by 9 hot plate uses 6504-022 element.
My timer will not set for short amounts of time?	You must turn knob on the timer past 2 and set back to desired time.
How do I change my Non-stick cover?	When unit is cool, pull cover off it is not attached.
Where can I get transformers?	They are no longer available. You need a hot rod conversion kit.
What kind of film do I use?	PVC stretch film for wrapping meat and produce, its chemical characteristics provide barriers to protect the product. Stretch film for pallet wrap is Polyethylene and not to be used on wrappers.

ABOUT HOT ROD

My hot rod is cold, what should I do?	<ul style="list-style-type: none">a) Check the fuse, replace if blown.b) Check the circuit board for loose wires.c) See page 2 for testing the Hot Rod Circuit Board.
My hot rod is not hot enough or too hot, what should I do?	<ul style="list-style-type: none">a) Check the circuit board, if potentiometer has been adjusted the rod will no longer work correctly.b) See page 2 for testing the Hot Rod Circuit Board.
My hot plate works but my hot rod doesn't?	<ul style="list-style-type: none">a) Hot Rod, Circuit Board and Fuse Holder work together.b) Hot Plate, Thermostat and Element work together.c) Hot Plate and Hot Rod are independent of each other.

ABOUT HOT PLATE

Why is the Hot Plate smoking?	That is excess protective coating on the heating element burning off and should last no more than 10 or 15 minutes.
My hot plate is cold?	Check element then thermostat and wires to thermostat.

****WHEN REPLACING THE HOT ROD OR CIRCUIT BOARD,
IT IS RECOMMENDED TO REPLACE BOTH SINCE THEY WORK TOGETHER.****

ELECTRICAL REQUIREMENTS

All Models are 110 Volts, 10 Amps.

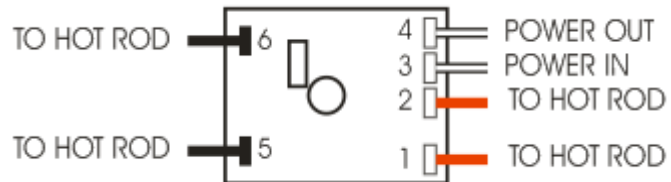

HOT ROD CIRCUIT BOARD TEST

A standard 115 volt neon circuit tester can be used for these tests.

CHECKING FUSES

Remove the fuse from their housing units located on the front of the electrical box. If a visual inspection does not verify a blown fuse check for continuity by using the meter to read across the two terminals of the fuse.

If the meter reading does not show continuity, replace the fuse.

CHECKING THE HOT ROD

With the power turned OFF, remove the red hot rod wires from Terminals 1 and 2. Using the meter, measure the resistance of the rod by connecting the leads of the meter to the red wires.

The meter should read between 130-136 ohms. If the reading is out of this range, replace the hot rod.

CHECKING THE CIRCUIT BOARD

After the hot rod and both the fuses have passed the above testing procedures, the circuit board can be tested.

With all the wires shown in the example circuit board (above) properly connected and the power ON, use the meter to test the voltage across Terminals 1 and 2. If there is no voltage being read, the board needs to be replaced.

THIS UNIT SHOULD NOT BE OPERATED IF ROD TEMPERATURE EXCEEDS 300 DEGREES FAHRENHEIT. IF SMOKE OR FUMES ARE DETECTED, DISCONTINUE USE

ELECTRICAL DIAGRAMS



FOR MODELS 102A, 104A, 107A

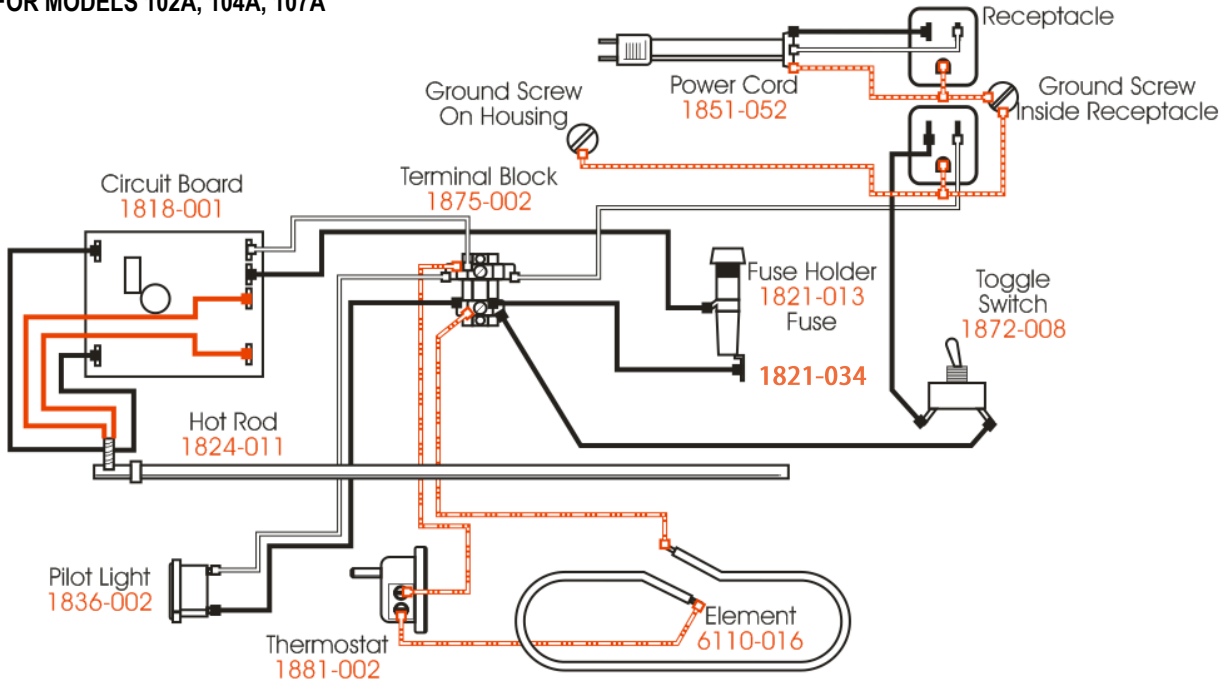

FOR MODEL 112A

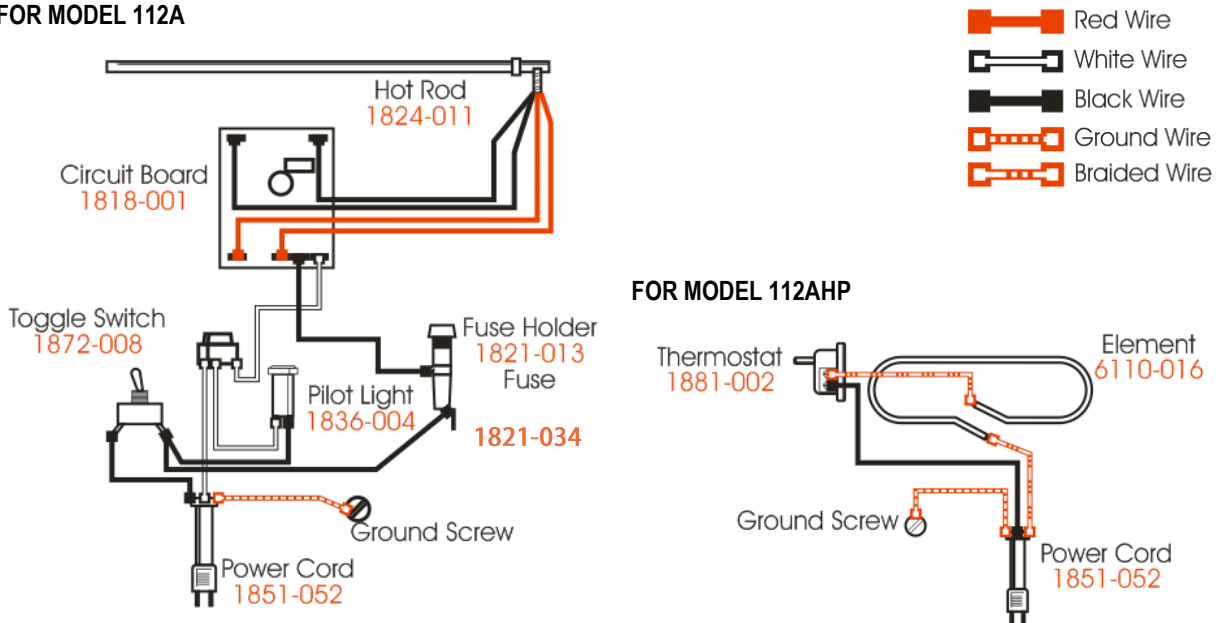

FOR MODEL 112AHP

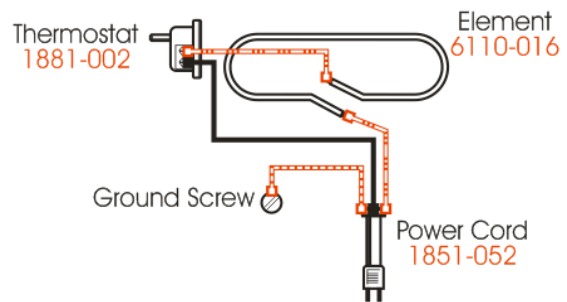

Revised 2017

ELECTRICAL BOX & HOT PLATE PARTS



TO SERVICE ELECTRICAL PARTS ON ELECTRICAL BOX:
Lift up the wrapping bridge, then remove the screws holding the electrical control housing to the base. Lift out and replace parts.

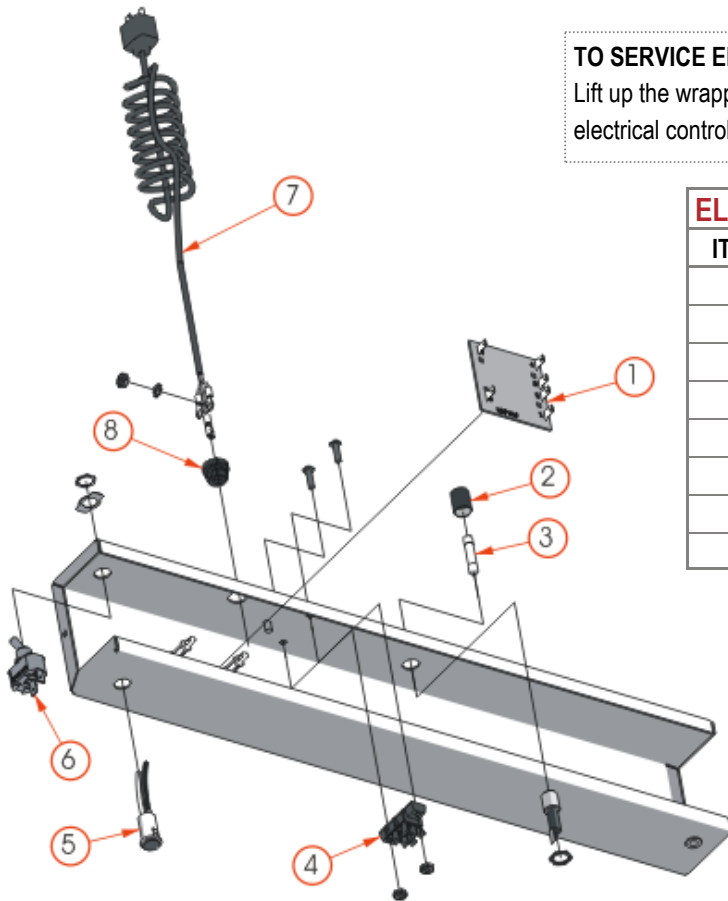

ELECTRICAL BOX REPLACEMENT PARTS

ITEM	PART #	DESCRIPTION
1	1818-001	Circuit Board
2	1821-013	Fuse Holder
3	1821-002	Fuse, 1 Amp AGC
4	1875-002	Terminal Block
5	1836-004	Pilot Light, Red
6	1872-008	Toggle Switch
7	1851-052	Power Cord, 5 Ft.
8	1869-003	Strain Relief

TO SERVICE ELECTRICAL PARTS ON HOT PLATE:
Remove from wrapper base and replace worn or defective parts.

HOT PLATE REPLACEMENT PARTS		
ITEM	PART #	DESCRIPTION
1	6305-076	Hot Plate, 6 by 15
	6305-079	Hot Plate, 8 by 15
2	6110-016	Element
3	6305-080	Element Support Plate
4	1881-002	B-200 Thermostat
5	2145-023	Knob

